

TECHNICAL MANUAL

OPERATOR'S AND ORGANIZATIONAL
MAINTENANCE MANUAL

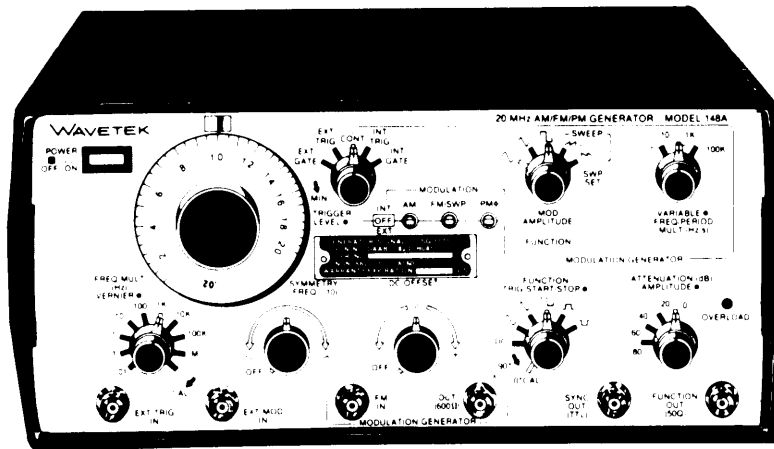

EQUIPMENT
DESCRIPTION
PAGE 1-3

OPERATOR'S
CONTROLS
PAGE 2-1

OPERATOR
PMCS
PAGE 2-4

OPERATION
PAGE 2-6

ORGANIZATIONAL
PMCS
PAGE 3-3

ORGANIZATIONAL
TROUBLESHOOTING
PAGE 3-3

ORGANIZATIONAL
MAINTENANCE
PROCEDURES
PAGE 3-5

SUBJECT
INDEX
PAGE INDEX-1

SIGNAL GENERATOR
SG-1171/U
(NSN 6625-01-133-6160)

**5****SAFETY STEPS TO FOLLOW IF SOMEONE IS THE VICTIM OF ELECTRICAL SHOCK****1****DO NOT TRY TO PULL OR GRAB THE INDIVIDUAL****2****IF POSSIBLE , TURN OFF THE ELECTRICAL POWER****3****IF YOU CANNOT TURN OFF THE ELECTRICAL POWER, PULL, PUSH, OR LIFT THE PERSON TO SAFETY USING A WOODEN POLE OR A ROPE OR SOME OTHER INSULATING MATERIAL****4****SEND FOR HELP AS SOON AS POSSIBLE****5****AFTER THE INJURED PERSON IS FREE OF CONTACT WITH THE SOURCE OF ELECTRICAL SHOCK, MOVE THE PERSON A SHORT DISTANCE AWAY AND IMMEDIATELY START ARTIFICIAL RESUSCITATION**

WARNING

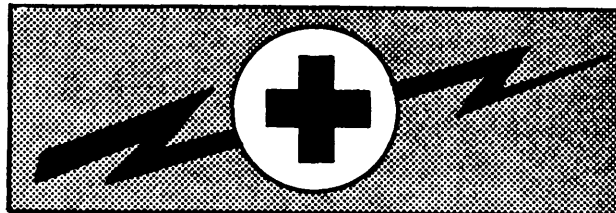

HIGH VOLTAGE

is used in the operation of this equipment

DEATH ON CONTACT

may result if personnel fail to observe safety precautions

Never work on electronic equipment unless there is another person nearby who is familiar with the operation and hazards of the equipment and who is competent in administering first aid. When the technician is aided by operators, he must warn them about dangerous areas.

Whenever possible, the power supply to the equipment must be shut off before beginning work on the equipment. Take particular care to ground every capacitor likely to hold a dangerous potential. When working inside the equipment, after the power has been turned off, always ground every part before touching it.

Be careful not to contact high-voltage connections or 115 volt ac input connections when installing or operating this equipment.

Whenever the nature of the operation permits, keep one hand away from the equipment to reduce the hazard of current flowing through the body,

Warning: Do not be misled by the term "low voltage". Potentials as low as 50 volts may cause death under adverse conditions.

For Artificial Respiration, refer to FM 21-11.

WARNING

Adequate ventilation should be provided while using TRICHLOROTRIFLUORETHANE. Prolonged breathing of the vapor should be avoided. Do not use near heat or open flame; the products of decomposition are toxic and irritating. Since TRICHLOROTRIFLUOROETHANE dissolves natural oils, prolonged contact with the skin should be avoided. When necessary, use gloves, sleeves, and aprons which the solvent cannot penetrate. If the solvent is taken internally, consult a physician immediately.

WARNING

Compressed air shall not be used for cleaning purposes except where reduced to less than 29 pounds per square inch (psi) and then only with effective chip guarding and personnel protective equipment. Do not use compressed air to dry parts when TRICHLOROTRIFLUOROETHANE has been used. Compressed air is dangerous and can cause serious bodily harm if protective means or methods are not observed to prevent chip or particle (of whatever size) from being blown into the eyes or unbroken skin of the operator or other personnel.

WARNING

To avoid electrical shock, be extremely careful when making required measurements and adjustments. Serious injury or death may result from contact with the voltages within the range of this instrument.

**TECHNICAL MANUAL
NO. 11-6625-3051-12**

**HEADQUARTERS
DEPARTMENT OF THE ARMY
WASHINGTON, DC., 6 September 1985**

**OPERATOR'S AND ORGANIZATIONAL MAINTENANCE MANUAL
SIGNAL GENERATOR SG-1171/U
(NSN 6625-01-133-6160)**

REPORTING ERRORS AND RECOMMENDING IMPROVEMENTS

You can help improve this manual. If you find any mistakes or if you know of away to improve the procedures, please let us know. Mail your letter, DA Form 2028 (Recommended Changes to Publications and Blank Forms), or DA Form 2028-2 located in back of this manual direct to: Commander, US Army Communications—Electronics Command and Fort Monmouth, ATTN: AMSEL-ME-MP, Ft. Monmouth, NJ 07703-5007. A reply will be furnished direct to you.

		Page
	HOW TO USE THIS MANUAL	iii
CHAPTER 1	INTRODUCTION	1-1
Section I	General Information	1-1
II	Equipment Description	1-3
III	Technical Principles of Operation	1-7
CHAPTER 2	OPERATING INSTRUCTIONS	2-1
Section I	Description and Use of Operator's Controls, Indicators and Connectors	2-1
II	Operator Preventive Maintenance Checks and Services (PMCS)	2-4
III	Operation Under Usual Conditions	2-6
IV	Operation Under Unusual Conditions	2-12
CHAPTER 3	ORGANIZATIONAL MAINTENANCE	3-1
Section I	Repair Parts, Special Tools, TMDE, and Support Equipment	3-1
II	Service Upon Receipt	3-1
III	Preventive Maintenance Checks and Services (PMCS)	3-3
IV	Troubleshooting	3-3
V	Maintenance Procedures	3-5
VI	Preparation for Storage or Shipment	3-10

CONTENTS — Continued

APPENDIX A	REFERENCES	A-1
B	MAINTENANCE ALLOCATION CHART (MAC)	B-1
C	COMPONENTS OF END ITEM AND BASIC ISSUE ITEMS LISTS (Not Applicable)	
D	ADDITIONAL AUTHORIZATION LIST	D-1
E	EXPENDABLE SUPPLIES AND MATERIALS LIST	E-1
	SUBJECT INDEX	INDEX-1

HOW TO USE THIS MANUAL

Spend a few minutes looking through this manual. It has a new look that is very different from the manuals you have been using. You will find the new look is a lot easier to use, and you can find what you are looking for a lot faster. We got rid of as many words as we could and put in pictures to aid in showing just about everything you will be doing to operate and maintain your equipment. So HOW DO YOU USE THIS MANUAL?

Like this:

1. Suppose you want to operate the signal generator.
2. Look at the cover and you will see index boxes near the right-hand edge with subject titles next to them. You will find "OPERATION PAGE 2-6." You can skip over to page 2-6.

OR

3. Bend the pages a bit and look at the edges. You will see black bars on some of the pages that are lined up with the index boxes on the cover.
4. If you put your thumbnail on the black bar that is lined up with the box on the cover for OPERATION and open the manual, you will be on page 2-6.

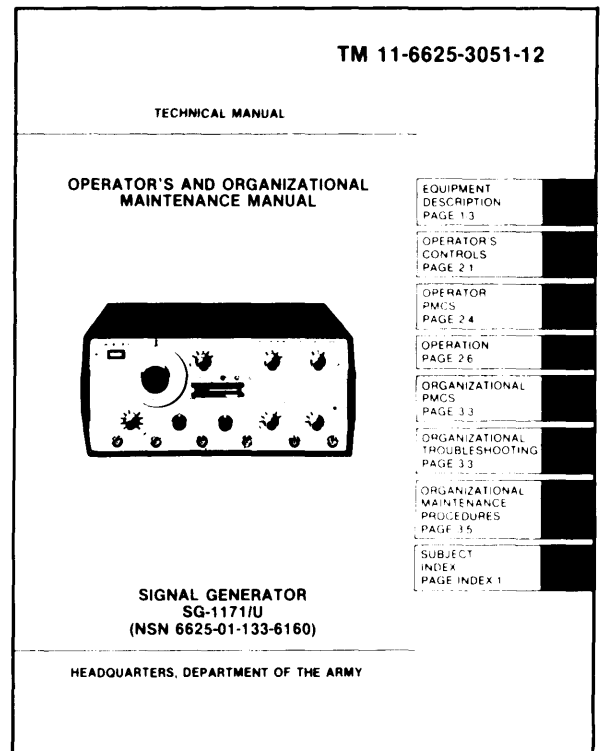

EL8ZX001

5. On page 2-6, you will find Operation Under Usual Conditions. Now you are ready to begin.
6. Look at the procedures.
7. Each procedure has one or more steps with a picture to show you where to look and what to look at.
8. Notice the numbered arrows. These are called index numbers. As you read each step, we will tell you where to look by including the index number (in parentheses) after the name of each thing we call out.

TM 11-6625-3051-12

Table 2-4. Continuous Mode Control Setup Positions

Control	Position
FREQUENCY Dial	1.0
FREQ MULT	1K
VERNIER	Clockwise
SYMMETRY	OFF (detent)
DC OFFSET	OFF (detent)
FUNCTION (lower switch row)	Square Wave
TRIG START/STOP	0° CAL (detent)
ATTENUATION	0/20
AMPLITUDE (lower switch row)	Clockwise
Generator Mode (EXT GATE, etc)	CONT
TRIGGER LEVEL	Counterclockwise
MODULATION Switches	OFF
FUNCTION (Modulation Generator)	Sine Wave
MOD AMPLITUDE	Counterclockwise
FREQ PERIOD MULT	10/1K
VARIABLE	Clockwise

(7) Set FUNCTION switch (7) to produce desired waveform.

(8) Internal Triggered Mode Operation is basically the same as in the continuous mode with the exception that the signal generator will output a single cycle of the main frequency for each internal trigger. The internal modulation generator can be varied to provide triggers at different intervals. Use the following steps to operate the signal generator in the internal triggered mode.

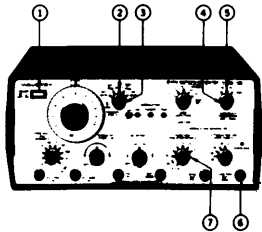

1 2 3 4 5
7 8

EL821005

2-6

EL8ZX002

You can also use the Table of Contents in the front of the manual or the Subject Index in the back to find the information you want. Either one will lead you to the page number of the procedure you need.

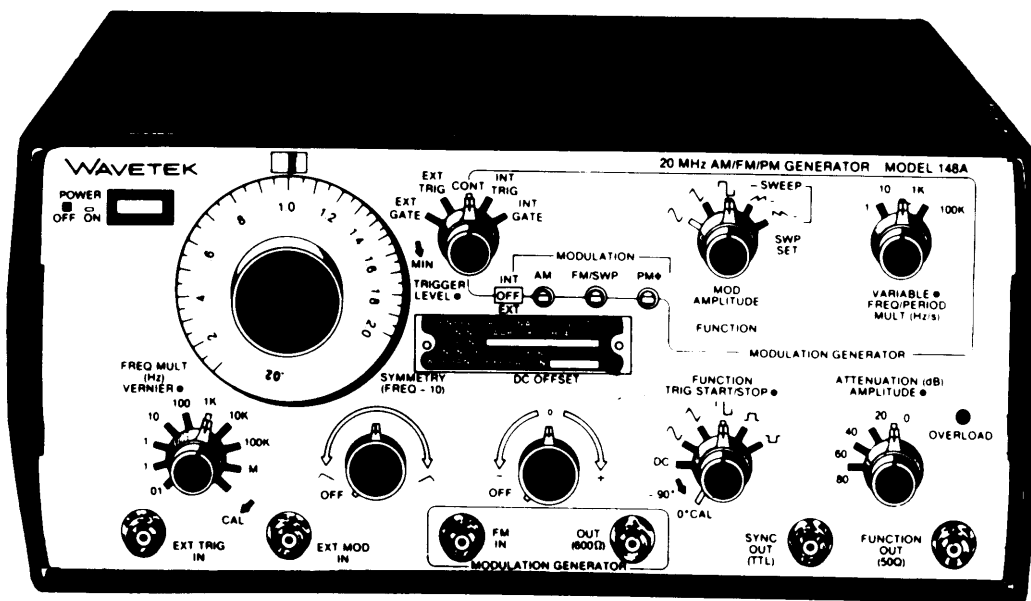

EL8ZX003

Figure 1-1. Signal Generator SG-1171/U

CHAPTER 1

INTRODUCTION

	Para	Page
Consolidated Index of Army Publications and Blank Forms	1-2	1-1
Destruction of Army Materiel to Prevent Enemy Use... Equipment Data	1-4	1-2
Instrument Characteristics, Capabilities, and Features. List of Abbreviations	1-11	1-4
Maintenance Forms, Records, and Reports	1-10	1-3
Nomenclature Cross-Reference List	1-9	1-3
Operating Principles	1-3	1-1
Preparation for Storage of Shipment	1-8	1-2
Reporting Equipment Improvement Recommendations (EAR)	1-13	1-7
Safety, Care, and Handling	1-5	1-2
Scope	1-6	1-2
Warranty Information	1-7	1-7

Section I. GENERAL INFORMATION

1-1. SCOPE.

- a. *Type of Manual:* Operator's and Organizational Maintenance Manual.
- b. *Equipment Name and Model Number:* Signal Generator SG-1171/U.
- c. *Purpose of Equipment:* To provide precision source of sine, square, triangle, ramp and pulse waveforms for use in support of radio receivers, transmitters and associated electronic equipment.

1-2. CONSOLIDATED INDEX OF ARMY PUBLICATIONS AND BLANK FORMS.

Refer to the latest issue of DA Pam 310-1 to determine whether there are new editions, changes, or additional publications pertaining to the equipment.

1-3. MAINTENANCE FORMS, RECORDS AND REPORTS.

- a. *Reports of Maintenance and Unsatisfactory Equipment.* Department of the Army forms and procedures used for equipment maintenance will be those prescribed by DA Pam 738-750 as contained in Maintenance Management Update.
- b. *Report of Packaging and Handling Deficiencies.* Fill out and forward SF 364 [Report of Discrepancy (ROD)] as prescribed in AR 735-11-2/DLAR4140.55/NAVMATINST 4355.73A/AFR 400-54/MCO 4430.3F.

c. *Discrepancy in Shipment Report (DISREP) (SF 361)*. Fill out and forward Discrepancy in Shipment Report (DISREP)(SF 361) as prescribed in AR 55-38/NAVSUPINST 4610.33C/AFR 75-18/MCO P4610.19D/DLAR 4500.15.

1-4. DESTRUCTION OF ARMY MATERIEL TO PREVENT ENEMY USE.

Demolition and destruction of electronic equipment will be under direction of the commander and in accordance with TM 750-244-2.

1-5. PREPARATION FOR STORAGE OR SHIPMENT.

For information and instructions on packaging and administrative storage, refer to Chapter 3, Section VI

1-6. REPORTING EQUIPMENT IMPROVEMENT RECOMMENDATIONS (EIR).

If your signal generator needs improvement, let us know. Send us an EIR. You, the user, are the only one who can tell us what you don't like about your equipment. Let us know why you don't like the design. Submit a Quality Deficiency Report, form SF-368. Mail it to: Commander, US Army Communications — Electronics Command and Fort Monmouth, ATTN: AMSEL-ME-MP, Fort Monmouth, NJ 07703-5007. We'll send you a reply.

1-7. WARRANTY INFORMATION.

Signal Generator SG-1171/U is warranted for one year. The warranty expiration date is on the instrument name plate. Promptly report all defects to your supervisor for possible warranty repair.

1-8. NOMENCLATURE CROSS-REFERENCE LIST.

Common names will be used when major components of the signal generator are mentioned in this manual.

NOTE

Official nomenclature must be used when filling out report forms or looking up Technical Manuals

Common Name

Signal generator

Official Nomenclature

Signal Generator SG-1171/U

1-9. LIST OF ABBREVIATIONS.

This list identifies abbreviations and descriptions that are used in this manual.

SYNC	Synchronous or Synchronized
CW	Clockwise
CCW	Counterclockwise
AM	Amplitude Modulation
FM	Frequency Modulation
PM	Phase Modulation
TTL	Transistor transistor logic. Voltage range of 0 to + 0.4 volts (logic low) and 2.4 to 5.0 volts (logic high).
COAX	Coaxial
LED	Light Emitting Diode
TRICHLOR	Trichlorotrifluoroethane
MOD	Modulation or Modulator
GEN	Generator

SECTION II EQUIPMENT DESCRIPTION**1-10. INSTRUMENT CHARACTERISTICS, CAPABILITIES, AND FEATURES.**

- a. *Characteristics.* Signal Generator SG-1171/U is a precision source of:
- Sine Waves
 - Triangle Waves
 - Square Waves
 - Ramp Signals
 - Modulated Signals
 - DC Offset Voltage
- b. *Capabilities and Features.* Signal Generator SG-1171/U capabilities and features are as follows:
- Waveform symmetry continuously variable and controlled at front panel.
 - Output signal amplitude and frequency controlled at front panel.
 - Contains internal modulation generator that provides three modulation modes. These modes are frequency, amplitude, and phase.
 - Able to operate in five operational modes. These modes are continuous, internal triggered, external triggered, internal gated, and external gated.
 - Triggered and gated waveform start/stop point selectable from – 90 to +90 degrees.
 - Main waveform output may be attenuated and offset. A TTL level sync pulse output runs at main generator frequencies.
 - Modulation generator waveform output may be attenuated.
 - Main generator and modulation generator frequencies manually controlled at front panel or by external voltages.
 - External sync input from rear panel BNC connector.

1-11. EQUIPMENT DATA.

WEIGHT AND DIMENSIONS

Weight:
Net: 10 lb (4.55 kg)
Shipping: 12.3 lb (5.59 kg)

Dimensions:
Height: 5.25 in. (13.34 cm)
Width: 11.25 in. (28.58 cm)
Depth: 10.75 in. (27.31 cm)

OPERATING REQUIREMENTS

Power: 30 VA maximum.
100 to 120 Vac or 220 to 240 Vac wired internally at factory,
48 to 66 Hz.

Operating Temperature: 32° to 122°F (0° to 50°C)
25 ± 5°C for specified operation.

Relative Humidity: Less than 95% at 25°C at sea level (non-condensing).

Altitude: Sea level to 10,000 ft.

PERFORMANCE CHARACTERISTICS

Main Generator:

Waveforms: Selectable sine, triangle, square, positive pulse, and negative pulse. Waveforms have variable symmetry and dc offset capability.

Operational Modes:

Continuous: Main generator oscillates continuously at selected frequency.

External Trigger: Main generator outputs one cycle of selected frequency when triggered by external signal.

External Gate: Main generator outputs selected frequency for duration of positive state of gate signal plus time to complete last cycle of frequency.

Internal Trigger: Main generator outputs one cycle of selected frequency when triggered by signal from internal modulation generator.

Internal Gate: Main generator outputs selected frequency for duration of positive state of gate signal from internal modulation generator plus time to complete last cycle of frequency.

Modulation Modes:

Internal Modulation:

- Amplitude Modulation: Main generator output modulated by sine, triangle, or square waves.
- Frequency Modulation: Main generator output modulated by positive and negative ramps used as sweep voltages.
- Phase Modulation: Main generator output modulated by sine, triangle, or square waves. Amplitude of modulating signal shifts phase of main generator output $\pm 50^\circ$.

External Modulation:

- Amplitude Modulation: Main generator output modulated by sine, triangle, or square waves from EXT MOD IN front panel connector.
- Frequency Modulation: Main generator output modulated by changes in voltage levels at FM IN front panel connector.
- Phase Modulation: Main generator output modulated by sine, triangle, or square waves from EXT MOD IN front panel connector. Amplitude of modulating signal shifts phase of main generator output $\pm 50^\circ$.

Frequency Range: Selectable from 0.0002 Hz to 20 MHz in 10 overlapping ranges. VERNIER control varies frequency approximately 1% in any range.

Function Outputs: Selectable sine, triangle, and square waves variable to 15 Vp-p into 50 Ω . Selectable positive and negative pulses variable to 7.5 V peak into 50 Ω . All waveforms and dc can supply up to 150 mA current output.

Start/Stop Range: Sine and triangle waveform start/stop point trigger range approximately $\pm 90^\circ$ up to 2 MHz.

DC Offset/Output: Front panel selectable. DC offset plus signal adjustable to more positive than + 7.5 V and more negative than - 7.5 V into 50 Ω . DC output adjustable to more positive than + 7.2 V and more negative than - 7.2 V into 50 Ω .

External Modulation Input:

- AM: Sensitivity of 1 volt input to provide 3 volts of modulation. Input impedance is greater than 2.5 k Ω .
- FM: Sensitivity of 1 volt input to sweep 20% of selected frequency range. Input impedance is 5 k Ω .
- PM: Sensitivity of 1 volt input for 10 $^\circ$ of phase shift. Input impedance is 50 k Ω .

Symmetry:	Main generator outputs continuously variable from 1:19 to 19:1 for variable duty cycle pulses, sawtooth ramps, and non-symmetrical sine waves.
Sync Output:	TTL level (0 to + 5 V) duplicate of FUNCTION OUT signals. Can supply 10 TTL loads.
Triggers and Gates:	
Input Signal:	Minimum of 1 Vp-p at a maximum dc level of between + 10 V and -10V.
Input Impedance:	10 k Ω , 33 pf
Pulse Width:	25 ns minimum
Repetition Rate:	10 MHz maximum
Frequency Precision:	
Dial Accuracy:	\pm (1% of dial setting plus 1% of full range) on X100 thru X1 M ranges and \pm (2% of dial setting plus 2% of full range) on X.01 thru X10 and X10M ranges.
Time Symmetry:	\pm 5% on all ranges and dial settings except \pm 0.5% between dial settings of .2 to 2.0 on the X100 thru X100K ranges.
Amplitude Precision:	
Frequency Change:	Sine variation less than \pm 0.1 dB thru X100K range, \pm 0.5 dB on X1M range, and \pm 3 dB on X10M range.
Step Attenuator Change:	\pm 0.3 dB per 20 dB steps at 2 kHz.
Waveform Characteristics:	
Sine Distortion:	Less than 0.5% on X100 thru X10K ranges and less than 1% on X.01 thru X10 and X100K ranges. All harmonics 30 dB down on X1 M range and 26 dB down on 10M range.
Square Wave Rise/Fall:	Less than 25 ns for 15 Vp-p into 50 Ω load.
Triangle Distortion:	Less than 15% up to 2 MHz.
External Sync Input:	Minimum signal of 1 Vp-p to maximum of 20 Vp-p. Input impedance of 2 k Ω with 10 pf. Frequency of sync signal must be within 1% of main generator frequency.
Modulation Generator:	
Waveforms:	Selectable sine, triangle, square, positive ramp, and negative ramp.

Frequency Range:	0.1 Hz to 100 kHz for sine, triangle, and square waves. 0.2 Hz to 200 kHz (ramp function doubles range setting) for positive and negative ramps.
Output (600 Ω):	Fixed level 10 Vp-p ground referenced signal for sine, triangle, and square waves. Fixed level 5 Vp-p signal from 0 to + 5 V for positive and negative ramps.
Frequency Modulation:	Sensitivity of 20% of selected range per input volt. Input impedance of 5 k Ω .
Waveform Characteristics:	
Sine Distortion:	Less than 5% on all ranges.
Time Symmetry:	Less than 1% from 1 Hz to 10 kHz and less than 5% from 0.1 Hz to 100 kHz.

1-12. SAFETY, CARE, AND HANDLING.

Observe all WARNINGS, CAUTIONS, and NOTES in this manual. This equipment can be extremely dangerous if these instructions are not followed.

Section III. TECHNICAL PRINCIPLES OF OPERATION

1-13. OPERATING PRINCIPLES.

The Signal Generator SG-1171/U has give basic functional circuits as shown below. The five basic functional circuits will be operated in a similar way in each of the operating modes.

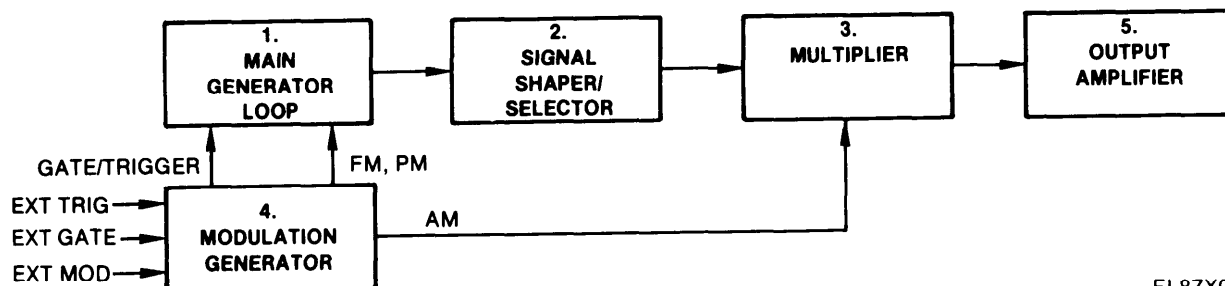

EL8ZX013

a. *Continuous Mode.* All five basic functional circuits are used in this mode and can be modulated or unmodulated. The following paragraphs describe this mode and the block diagram shows signal flow:

- (1) Main Generator Loop. Generates triangle and square waves. Controls main generator frequency of operation. Fm or PM inputs from modulation generator will frequency or phase modulate the main generator loop output when selected. Produces triangle wave and square wave for input to Signal Shaper/Selector.
- (2) Signal Shaper/Selector. Receives modulated or unmodulated triangle and square waves from main generator loop. Uses triangle waveform to develop sine wave. Clips square wave to develop positive and negative pulse waveforms.
- (3) Multiplier. Receives FM modulated, PM modulated, or unmodulated triangle, sine, square, and positive or negative pulse waveforms from signal shaper/selector circuit. Mixes an AM signal (when selected) from modulation generator to the unmodulated signal from the signal shaper/selector for AM modulation. Outputs low level signal to output amplifier.
- (4) Modulation Generator. Generates internal FM or PM signals for modulating the main generator loop for FM and/or PM modulation. Also generates an internal AM signal for mixing in the multiplier for AM modulation. Front panel controls select either internal or external AM, FM, or PM modulating signals.
- (5) Output Amplifier. Receives low level function waveforms from multiplier. Amplifies low level function waveforms to power level necessary to drive external equipment.

b. *Infernal Trigger Mode.* Same as continuous mode but with the following differences:

- (1) Main Generator Loop. Each internal trigger signal from modulation generator enables main generator loop for one complete cycle of selected frequency.
- (2) Modulation Generator. Provides an internal trigger signal to main generator loop for internal trigger operation.

c. *External Trigger Mode.* Same as continuous mode but with the following differences:

- (1) Main Generator Loop. Each external trigger signal from modulation generator enables main generator loop for one complete cycle of selected frequency.
- (2) Modulation Generator. Accepts trigger signals from external sources. Routes external trigger signal to main generator loop for external triggered operation.

d. *Infernal Gate Mode.* Same as continuous mode but with the following differences:

- (1) Main Generator Loop. Each internal gate signal from modulation generator enables main generator loop for duration of internal gate pulse and the completion of the last cycle started of selected frequency.
- (2) Modulation Generator. Provides internal gate signal to main generator loop for internal gated operation.

e. *External Gate Mode.* Same as continuous mode but with the following differences:

- (1) Main Generator Loop. Each external gate signal from modulation generator enables main generator loop for duration of external gate pulse and the completion of the last cycle started of selected frequency.
- (2) Modulation Generator. Accepts gating signals from external sources. Routes external gate signal to main generator loop for external gated operation.

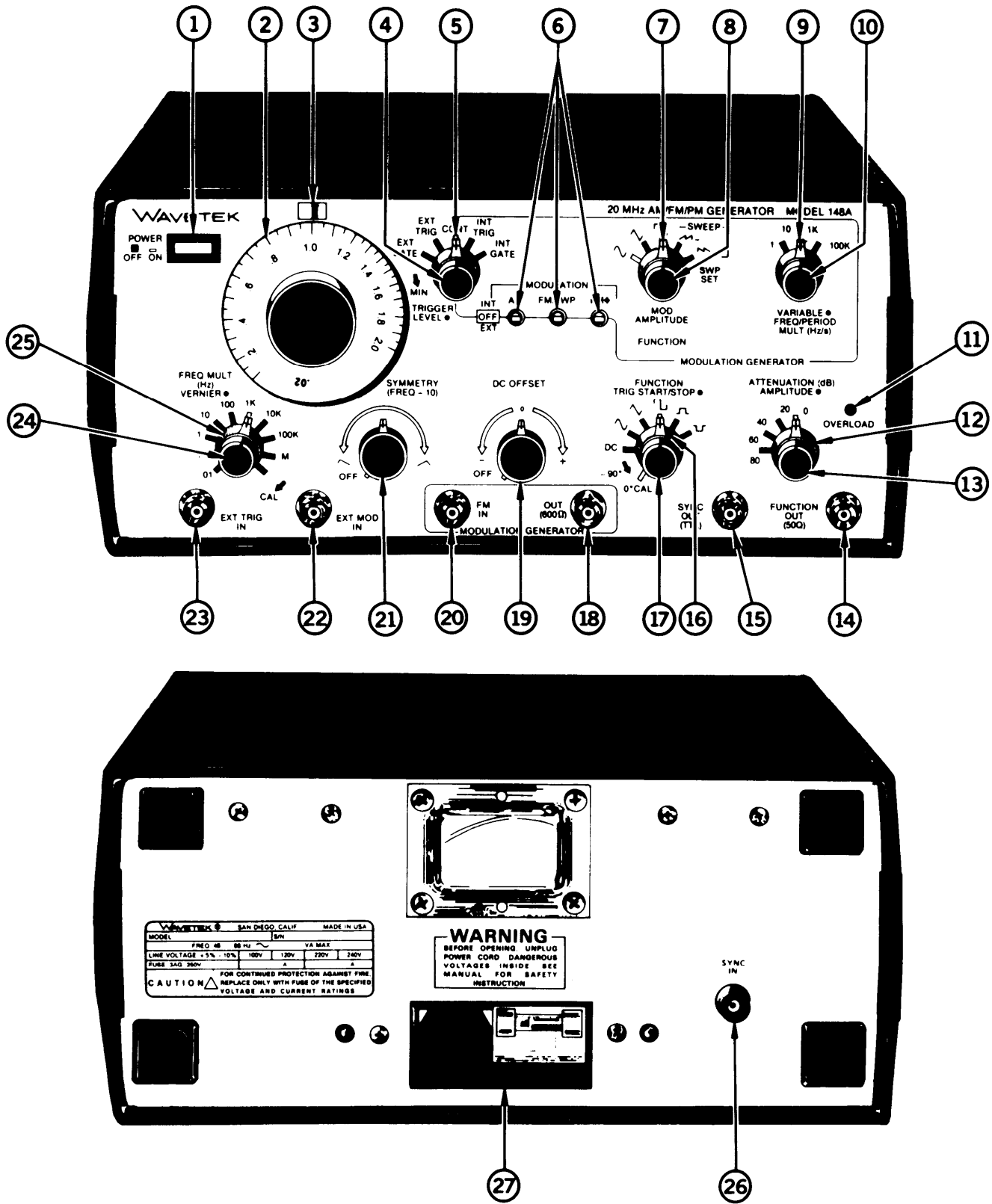

EL8ZX004

Figure 2-1. Operator's Controls, Indicators, and Connectors.

CHAPTER 2

OPERATING INSTRUCTIONS

	Para	Page
Controls, Indicators and Connectors	2-1	2-1
Operating Procedures	2-5	2-7
Operation in Dusty or Sandy Areas	2-7	2-12
Operation in Extreme Heat....	2-6	2-12
Operation in Humid Conditions.	2-8	2-12
PMCS Procedures	2-3	2-4
Preparation For Use	2-4	2-6

Section 1. DESCRIPTION AND USE OF OPERATOR'S CONTROLS, INDICATORS, AND CONNECTORS

2-1. CONTROLS, INDICATORS, AND CONNECTORS.

Operator's controls, indicators, and connectors are shown in figure 2-1 and described in table 2-1.

Table 2-1. Operator's Controls, indicators, and Connectors

Key	Control, Indicator, or Connector	Function
1	POWER OFF/ON Switch	Turns signal generator ON or OFF.
2	Frequency Dial	Varies frequency of main generator. Setting on dial multiplied by setting of FREQ MULT (Hz) switch. VERNIER control changes dial setting by 1%.
3	Dial Indicator Light	Highlights frequency "set line" and gives power ON indication.
4	TRIGGER LEVEL Control	Sets minimum level for both internal and external trigger enable signals.
5	Mode Switch	Selects main generator operating mode.
	EXT GATE	External signal starts main generator output. Output continues while external signal is high. Stops when external signal falls below trigger level setting.
	EXT TRIGGER	External signal starts main generator for one cycle each time external signal exceeds trigger level setting.
	CONT	Main generator gives continuous output.

Table 2-1. Operator's Controls, Indicators, and Connectors (Continued)

Key	Control, Indicator, or Connector	Function
	INT TRIG INT GATE	Signal from modulation generator starts main generator for one cycle each time trigger level setting is exceeded. Internal signal from modulation generator starts main generator each time trigger level setting is exceeded. Operation continues while internal signal is high and stops when internal signal falls below trigger level setting.
6	MODULATION Switches AM FM/SWP PM(\emptyset)	Selects type and source of modulation signals. Selects internal or external amplitude modulation. Selects internal or external frequency or sweep modulation. Selects internal or external phase modulation.
7	FUNCTION Switch (Sine) (Triangle) (Square) (Positive ramp) (Negative ramp)	Selects desired modulation generator waveform. Modulation generator provides sine waveform. Modulation generator provides triangle waveform. Modulation generator provides square waveform. Modulation generator provides sweep voltage starting at a low level and increasing to a high level. Modulation generator provides sweep voltage starting at a high level and decreasing to a low level.
8	MOD AMPLITUDE Control	Varies output level of modulation generator.
9	FREQ/PERIOD MULT (Hz/s) Switch	Selects desired modulation generator operating frequency range.
10	VARIABLE Control	Varies frequency of modulation generator within range selected by FREQ/PERIOD MULT (Hz/s) switch.
11	OVERLOAD Indicator	Indicates that output amplifier limits (into 50 Ω) have been exceeded.
12	ATTENUATION (dB) Switch	Selects desired main generator output level attenuation range.
13	AMPLITUDE Control	Varies output signal within limits set by ATTENUATION (dB) switch.
14	FUNCTION OUT (50 Ω) Connector	Output source of main generator functions.

Table 2-1. Operator's Controls, Indicators, and Connectors (Continued)

Key	Control, Indicator, or Connector	Function
15	SYNC OUT (ITL) Connector	Output source of main generator TTL synchronization signal.
16	FUNCTION Switch DC (Sine) (Triangle) (Square) (Positive pulse) (Negative pulse)	Selects desired main generator output waveform. Main generator provides dc level output. Main generator provides sine wave output. Main generator provides triangle wave output. Main generator provides square wave output. Main generator provides positive pulse output. Main generator provides negative pulse output.
17	TRIG START/STOP Control	Sets main generator waveform start and stop points. Operates only in trigger and gate modes, and on sine and triangle waveforms of less than 2 MHz. A 0° CAL detent ensures standard waveforms start and stop and 0°.
18	OUT (600 Ω) Connector	Output of modulation generator functions.
19	DC OFFSET Control	Vertically offsets main generator waveform in all functions except DC. When FUNCTION switch is in DC position the DC OFFSET control varies polarity and level of DC output. An OFF detent ensures zero offset.
20	FM IN Connector	Provides external voltage input for frequency modulating the modulation generator.
21	SYMMETRY (FREQ ÷ 10) Control	Varies symmetry of main generator waveforms from 19:1 to 1:19. An OFF detent ensures 1:1 (50%) symmetry. Main generator frequency is divided by 10.
22	EXT MOD IN Connector	Provides external modulation signal input for modulating circuits. Controlled by MODULATION Switch.
23	EXT TRIG IN Connector	Provides external input for triggering and gating signal generator with external signal sources.
24	VERNIER Control	Provides fine frequency adjustment of frequency dial setting.
25	FREQ MULT (Hz) Switch	Selects one of ten frequency multipliers for frequency dial range.

Table 2-1. Operator’s Controls, Indicators, and Connectors (Continued)

Key	Control, Indicator, or Connector	Function
26	SYNC IN Connector	Provides external input for synchronizing signal generator with external signal source.
27	Power Receptacle	Provides for connection of operating power cord and protective fusing of input power.

Section II. OPERATOR PREVENTIVE MAINTENANCE CHECKS AND SERVICES (PMCS)

2-2. GENERAL.

Operator's Preventive Maintenance Checks and Services (PMCS) is the required inspection and care of your equipment necessary to keep it in good operating condition.

2-3. PMCS PROCEDURES.

a. *Tools, Materials, and Equipment Required for Preventive Maintenance.* No tools or equipment are required for operator preventive maintenance. The following cleaning materials will be useful to the operator.

- Lint-free cloths
- Trichlorotrifluoroethane

b. *Routine Checks and Services.* Routine checks and services are not listed in the PMCS table. They are things that you should do any time you see they must be done.

- Clean
- Check for complete and current changes to publications.
- Check for loose screws and connectors.

c. *Preventive Maintenance Checks and Services.* A PMCS table (table 2-2) appears at the end of this section. There are three categories or intervals of PMCS: B,D, and A. They head the INTERVAL columns of the PMCS table. A mark in one or more of the INTERVAL columns indicates the check and/or service that should be performed by you. The following is a list of PMCS table definitions;

- (1) “B” stands for “before”. “B” PMCS should always be performed before operation to make sure your equipment is ready to go. Pay close attention to the CAUTIONS and WARNINGS.
- (2) “D” stands for “during”. “D” PMCS is performed *during* operation. This will help you spot small troubles before they become big problems.
- (3) “A” stands for “after”. “A” PMCS should be performed *after* operation. Pay close attention to the CAUTIONS and WARNINGS.

- (4) If something does not work correctly, contact your supervisor or next higher level of maintenance.
 - (5) Always do your preventive maintenance in the same order.
 - (6) If anything looks wrong and you can't fix it, write it on your DA Form 2404. If you find something seriously wrong, report it to organizational maintenance RIGHT NOW.
- d. *Explanation of Columns.* The following is an explanation of the columns in table 2-2.
- (1) Item no. This column contains a number for each procedure to be performed. When reporting malfunctions or failures on DA Form 2404, Equipment Inspection and Maintenance Work sheet, place this number in the TM Item No. column.
 - (2) Interval. These columns tell you when to do a procedure. Each column that applies will contain a dot. Some procedures will have dots in more than one column.
 - (3) Item to be inspected/procedure. This column contains the name of the item to be inspected and tells how to perform the required checks and services on it. Carefully follow these instructions and perform them in the order listed.
 - (4) Equipment is not ready/available if:. This column tells you:
 - Why your equipment cannot be used.
 - Why there is a problem with any item that was inspected.
 - What the problem is with the procedure.

Table 2-2. Operator Preventive Maintenance Checks and Services

B = Before Operation

D = During Operation

A = After Operation

Item No.	Interval			Item To Be Inspected Procedures	Equipment is Not Ready/ Available If:
	B	D	A		
1.	•			Front Panel Controls a. Check that knobs are not cracked or broken.	Knobs are damaged.
	•			b. Check that switches are not loose.	Switches are loose.
	•			c. Check that switches turn easily and are aligned with the front panel markings.	Switches jam or are mis-aligned.
2.				Front Panel Connectors.	
	•			a. Check that connectors are not tarnished or dirty.	
	•			b. Check that connectors are not bent or loose.	Connectors are bent or loose.

Table 2-2. Operator Preventive Maintenance Checks and Services (Continued)

B = Before Operation

D = During Operation

A = After Operation

Item No.	Interval			Item To Be Inspected Procedures	Equipment is Not Ready/ Available If:
	B	D	A		
3.	•			Front Panel a. Check that front panel markings are complete and readable. b. Check that power indicator is lit when when POWER switch is turned on. c. Check that OVERLOAD indicator does not flash or remain lit after POWER switch is set to ON.	POWER indicator is not lit. OVERLOAD indicator flashes or remains lit.
4.	•			Rear Panel a. Check that connectors are not tarnished or dirty. b. Check that connectors are not bent or loose. c. Check that fuse is in place and is not blown. d. Check that voltage selector card is in place and displays the correct voltage number.	Connectors are bent or loose. Fuse is missing or appears blown. Card is missing or displays wrong voltage.
5.	•			Power Cable Check power cable for physical damage.	Cable is damaged.

Section III. OPERATION UNDER USUAL CONDITIONS

2-4. PREPARATION FOR USE.

a. Locate power receptacle fuse compartment (1) on rear panel of signal generator. Check that number visible (4) on printed circuit card (3) is correct for your power source. A list of input voltage range, card position, and fuse rating relationships is given in table 2-3. If number visible is not correct, contact next higher level of maintenance.

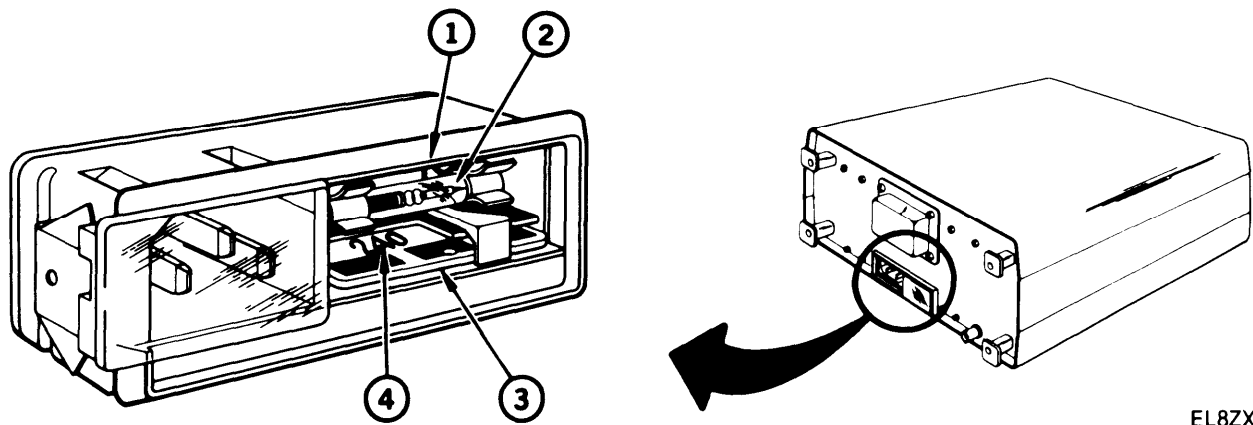

EL8ZX005

Table 2-3. Voltage Card Position and Fuses

Input Voltage	Card Position	Fuse
90 to 105	100	1/2 amp
108 to 126	120	1/2 amp
198 to 231	220	1/4 amp
216 to 252	240	1/4 amp

b. Check fuse (2) to see if it is missing, broken, or appears to be blown. If fuse is missing, broken or appears to be blown, contact next higher level of maintenance.

2-5. OPERATING PROCEDURES.

The following procedures cover Signal Generator SG-1171/U front and rear panel controls and connectors. Data is given to help you to operate the equipment in each of the five modes described in Chapter 1, Section III.

a. *Continuous Mode.* This mode can produce any one of five different waveforms. Each waveform will be repeated cycle after cycle. Each waveform can be modulated with either external or internal signals. Both internal and external modulation can be from amplitude, frequency, or phase sources. Only one of the many outputs possible in this mode will be produced in the following steps.

- (1) Set POWER OFF/ON switch (1) to OFF. (Refer to figure 2-1)
- (2) Connect signal generator power cable to power source and to signal generator power receptacle.
- (3) Connect a 50 ohm BNC to BNC coaxial cable from the FUNCTION OUT (50 Ω) connector (14). Terminate remaining end with a 50 ohm feedthrough load.
- (4) Connect terminated end of BNC cable to test equipment.
- (5) Set POWER OFF/ON switch (1) to ON.
- (6) Set all controls to positions given in table 2-4. Use figure 2-1 to locate the desired controls and/or connectors.

Table 2-4. Continuous Mode Control Setup Positions

Control	Position
Frequency Dial	1.0
FREQ MULT	1K
VERNIER	Clockwise
SYMMETRY	OFF detent
DC OFFSET	OFF detent
FUNCTION (lower switch row)	Square Wave
TRIG START/STOP	0°CAL detent
ATTENUATION	0/20
AMPLITUDE (lower switch row)	Clockwise
Generator Mode (EXT GATE, etc)	CONT
TRIGGER LEVEL	Counterclockwise
MODULATION Switches	OFF
FUNCTION (Modulation Generator)	Sine Wave
MOD AMPLITUDE	Counterclockwise
FREQ/PERIOD MULT	10/1K
VARIABLE	Clockwise

(7) Set FUNCTION switch (12) to produce desired waveform.

b. *Internal Triggered Mode.* Operation is basically the same as in the continuous mode with the exception that the signal generator will output a single cycle of the main frequency for each internal trigger. The internal modulation generator can be varied to provide triggers at different intervals. Use the following steps to operate the signal generator in the internal triggered mode.

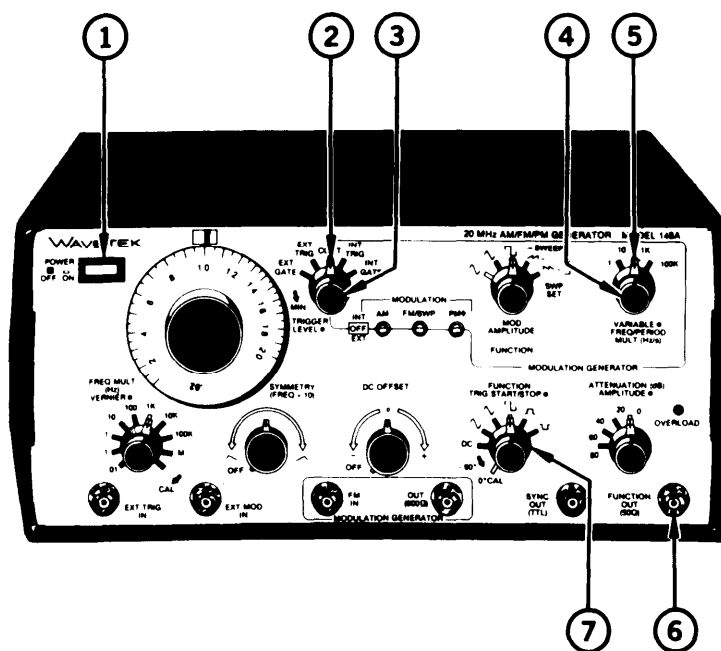

EL8ZX006

- (1) Set POWER OFF/ON switch (1) to OFF.
- (2) Connect signal generator power cable from signal generator power receptacle to power source.
- (3) Connect a 50 ohm BNC to BNC coaxial cable to the FUNCTION OUT (50 Ω) connector (6). Terminate remaining end with a 50 ohm feedthrough load.
- (4) Connect terminated end of BNC cable to test equipment.
- (5) Set POWER OFF/ON switch (1) to ON.
- (6) Set signal generator controls as indicated in table 2-4 (Continuous Mode Control Setup Positions).
- (7) Set FUNCTION switch (7) to desired waveform position.
- (8) Set generator Mode switch (2) to INT TRIG.
- (9) Adjust TRIGGER LEVEL control (3) to produce triggered output.
- (10) Rotate VARIABLE control (4) counterclockwise or FREQ/PERIOD MULT (Hz/s) switch (5) to adjust trigger interval.

c. *External Triggered Mode.* Operation is basically the same as in the internal triggered mode with the exception that the signal generator will output a single cycle of the main frequency for each external trigger input. The frequency is varied at the external trigger source to provide triggers of different intervals. Use the following steps to operate the signal generator in the external triggered mode.

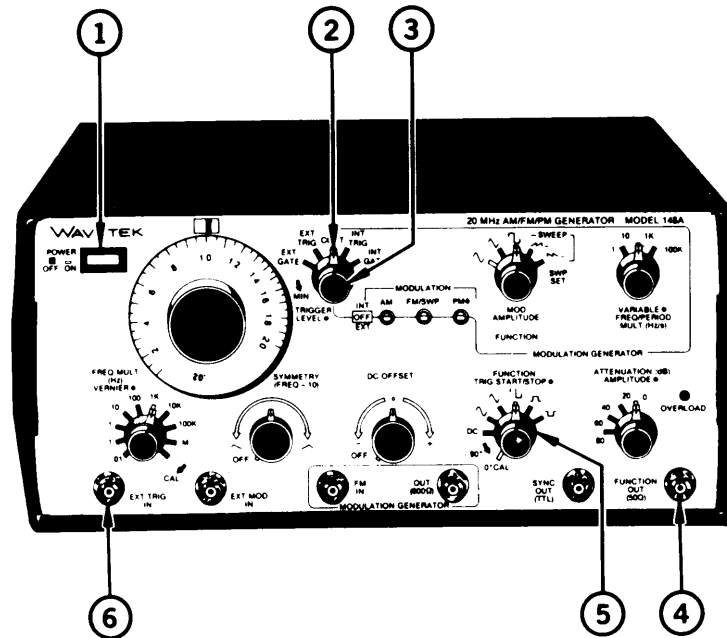

EL8ZX007

- (1) Set POWER OFF/ON switch (1) to OFF.
- (2) Connect signal generator power cable from signal generator power receptacle to power source.
- (3) Connect a 50 ohm BNC to BNC coaxial cable to the FUNCTION OUT (50 Ω) connector (4). Terminate remaining end with a 50 ohm feedthrough load.

- (4) Connect terminated end of BNC cable to test equipment,
- (5) Connect external trigger source to EXT TRIG IN connector (6),
- (6) Set POWER OFF/ON switch (1) to ON.
- (7) Set signal generator controls as indicated in table 2-4 (Continuous Mode Control Setup Positions),
- (8) Set FUNCTION switch (5) to desired waveform position,
- (9) Set Mode switch (2) to EXT TRIG position.
- (10) Rotate TRIGGER LEVEL control (3) to produce triggered output.
- (11) Adjust external trigger source frequency to change trigger interval.

d. *Internal Gated Mode.* In this mode of operation the signal generator will output a group of main generator waveforms for each gate. The modulation generator frequency is varied to provide gates of different widths and intervals, Use the following steps to operate the signal generator in the internal gated mode.

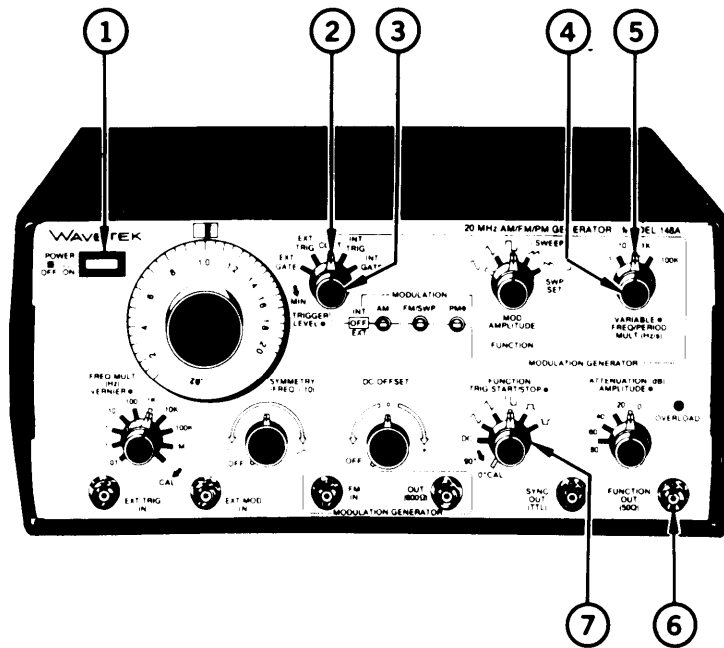

EL8ZX006

- (1) Set POWER OFF/ON switch (1) to OFF
- (2) Connect signal generator power cable to signal generator power receptacle and to power source
- (3) Connect a 50 ohm BNC to BNC coaxial cable to the FUNCTION OUT (50 Ω) connector (6). Terminate remaining end with a 50 ohm feedthrough load.
- (4) Connect terminated end of BNC cable to test equipment.
- (5) Set POWER OFF/ON switch (1) to ON.

- (6) Set signal generator controls as indicated in table 2-4 (Continuous Mode Control Setup Positions).
- (7) Set FUNCTION switch (7) to desired waveform position.
- (8) Set Mode switch (2) to INT GATE position.
- (9) Rotate TRIGGER LEVEL control (3) clockwise to produce output and adjust gate width.
- (10) Rotate VARIABLE control (4) or FREQ/PERIOD MULT (Hz/s) switch (5) to adjust gate interval.

e. *External/Gated Mode.* In this mode of operation the signal generator will output a group of waveforms for each gate. The gate source frequency is varied to provide gates of different intervals. Use the following steps to operate the signal generator in the external gated mode.

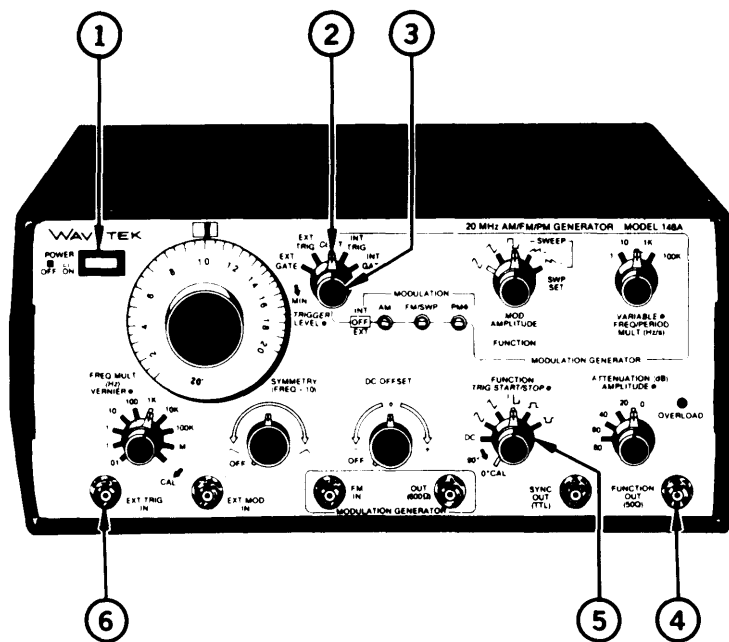

EL8ZX007

- (1) Set POWER OFF/ON switch (1) to OFF.
- (2) Connect signal generator power cable to signal generator power receptacle and to power source.
- (3) Connect a 50 ohm BNC to BNC coaxial cable to the FUNCTION OUT (50 Ω) connector (4). Terminate remaining end with a 50 ohm feedthrough load.
- (4) Connect terminated end of BNC cable to test equipment.
- (5) Connect external gate source to EXT TRIG IN connector (6).
- (6) Set POWER OFF/ON switch (1) to ON.
- (7) Set signal generator controls as indicated in table 2-4 (Continuous Mode Control Setup Positions).
- (8) Set FUNCTION switch (5) to desired waveform position.

- (9) Set Mode switch (2) to EXT GATE position.
- (10) Rotate TRIGGER LEVEL control (3) clockwise to produce output and adjust gate width.
- (11) Adjust external gate source frequency to control gate interval.

Section IV. OPERATION UNDER UNUSUAL CONDITIONS

2-6. OPERATION IN EXTREME HEAT.

- a. Protect the signal generator from direct sunlight.
- b. Do not obstruct the air flow around the signal generator, especially around the rear of the instrument.
- c. Do not leave the signal generator in the "ON" for longer than is necessary to perform indicated maintenance.

2-7. OPERATION IN DUSTY OR SANDY AREAS.

- a. Keep the signal generator as clean as is possible.
- b. Cover the signal generator when not in use.

2-8. OPERATION IN HUMID CONDITIONS.

- a. Take special precautions to keep the signal generator dry at all times.
- b. Check all connectors and metal chassis parts frequently for rust and/or corrosion.

CHAPTER 3 ORGANIZATIONAL MAINTENANCE

	Para	Page
Checking Unpacked Equipment	3-5	3-2
Common Tools and Test Equipment	3-1	3-1
Fuse Replacement	3-11	3-6
Knob Replacement and Alignment..	3-12	3-7
Preparation for Shipment	3-15	3-10
Preparation for Storage	3-16	3-10
Preventive Maintenance	3-6	3-3
Repair Parts	3-3	3-1
Special Tools and Test Equipment	3-2	3-1
Troubleshooting	3-9	3-4
Unpacking	3-4	3-1
Using the Troubleshooting Table	3-8	3-3

Section I. REPAIR PARTS, SPECIAL TOOLS, TMDE, AND SUPPORT EQUIPMENT

3-1. COMMON TOOLS AND EQUIPMENT.

Common tools and equipment required for organizational maintenance of Signal Generator SG-1171/U are listed in Appendix B (Maintenance Allocation Chart).

3-2. SPECIAL TOOLS, TMDE AND SUPPORT EQUIPMENT.

No special tools, TMDE, or support equipment are required.

3-3. REPAIR PARTS.

Repair parts are listed and illustrated in the Repair Parts and Special Tools List (RPSTL), TM 11-6625-3051-24P.

Section II. SERVICE UPON RECEIPT

3-4. UNPACKING.

Special design reusable packing material inside this shipping carton provides maximum protection for SG-1171/U Signal Generator. Avoid damaging carton and packing material during equipment unpacking. Use the following steps and figure 3-1 for unpacking the Signal Generator SG-1171/U:

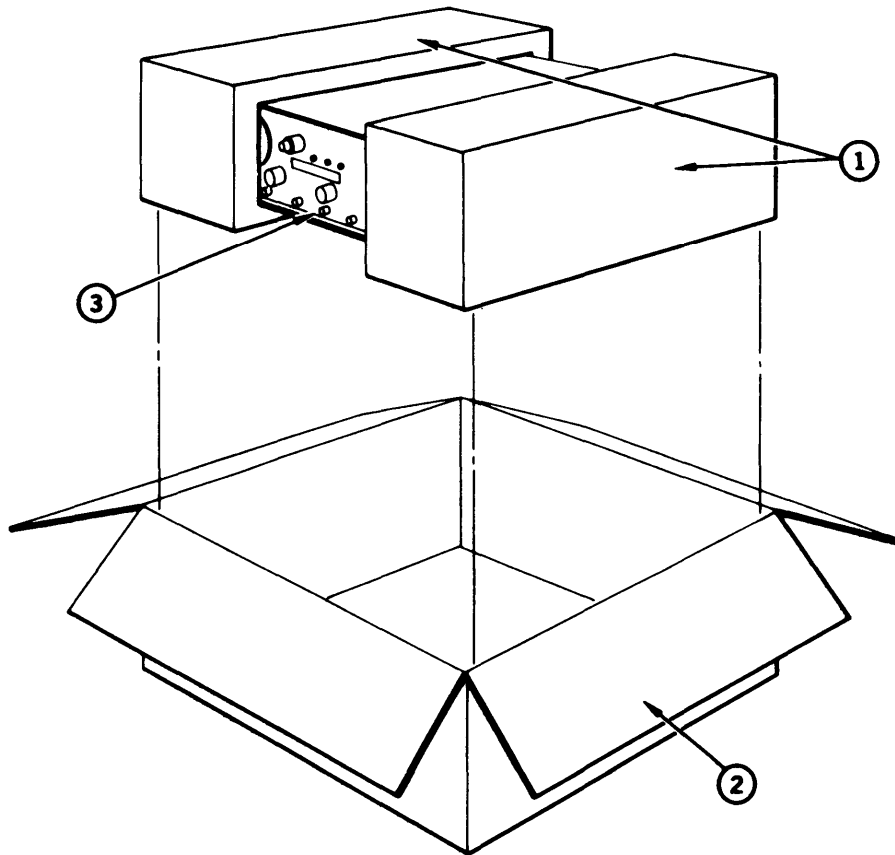

EL&ZX008

Figure 3-1. Unpacking Equipment

- a. Cut and remove paper sealing tape on carton top and open carton (2).
- b. Grasp signal generator (3) firmly while restraining shipping carton (2) and lift equipment and packing material (1) vertically.
- c. Place signal generator (3) and end cap packing material (1) on flat table or surface.
- d. Remove end cap packing material (1) while firmly supporting signal generator (3).
- e. Remove protective plastic bag from signal generator (3). Place desiccant bags back inside protective plastic bag.
- f. Place protective plastic bag and end cap packing material (1) inside shipping carton (2).
- g. Return shipping carton (2) to supply system.

3-5. CHECKING UNPACKED EQUIPMENT.

- a. Inspect equipment for damage incurred during shipment. If equipment has been damaged, report damage on Form SF 364, Report of Discrepancy.

- b. Check equipment against packing slip to see if shipment is complete. Report all discrepancies in accordance with instructions of DA Pam 738-750.
- c. Check to see whether equipment has been modified.

Section III. PREVENTIVE MAINTENANCE CHECKS AND SERVICES (PMCS)

3-6. PREVENTIVE MAINTENANCE

Preventive maintenance checks and services (PMCS) are done to find and to fix problems before they can cause major damage to the equipment. These checks and services are done by the operator for Signal Generator SG-1171/U. Refer to Chapter 2, Section II for Operator Preventive Maintenance Checks and Services.

Section IV. TROUBLESHOOTING

SYMPTOM INDEX

Signal Generator Symptom	Page
1. DIAL INDICATOR LIGHT NOT LIT....	3-4
2. NO OUTPUT	3-4
3. OVERLOAD INDICATOR LIT	3-5

3-7. GENERAL.

Troubleshooting at the organizational maintenance level requires you to locate any trouble as quickly as possible. The amount of troubleshooting you can do is based on what the Maintenance Allocation Chart says you can fix. Because of this, the only trouble symptoms you will find here are those that could be caused by faulty items you can fix.

NOTE

Before using the troubleshooting table, check your work order and talk to the operator, if possible, for a description of symptoms if trouble occurred while equipment was in operation.

3-8. USING THE TROUBLESHOOTING TABLE.

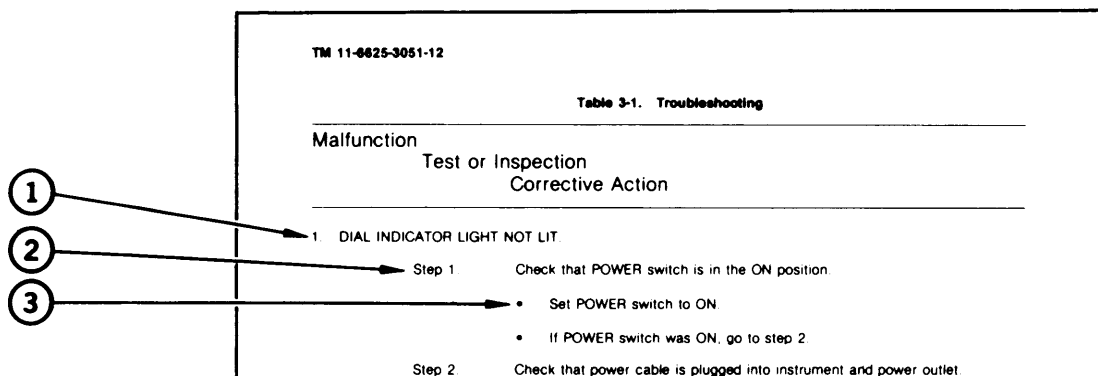

EL8ZX009

1. Malfunctions are those that cause symptoms seen or heard at the equipment without using test equipment.
2. Tests or inspections are procedure steps that isolate the damaged part.
3. Corrective action tells the technician what needs to be done to correct the problem.

3-9. TROUBLESHOOTING.

Table 3-1 lists the common malfunctions which you may find during the operation or maintenance of the signal generator. You should perform the tests, inspections, and corrective actions in the order listed.

NOTE

This manual cannot list all malfunctions that may occur, nor all the tests or inspections and corrective actions. If a malfunction is not listed or is not corrected by corrective actions, notify next higher level of maintenance.

Table 3-1. Troubleshooting

Malfunction	Test or Inspection	Corrective Action
1. DIAL INDICATOR LIGHT NOT LIT.	<p>Step 1. Check that POWER switch is in the ON position.</p> <ul style="list-style-type: none"> • Set POWER switch to ON. • If POWER switch was ON, go to step 2. <p>Step 2. Check that power cable is plugged into instrument and power outlet.</p> <ul style="list-style-type: none"> • Plug power cable into instrument and power outlet. • If power cable was plugged in, go to step 3. <p>Step 3. Check for blown fuse.</p> <ul style="list-style-type: none"> • If fuse is blown, set POWER switch to OFF and replace fuse (para 3-11). • If fuse is not blown, contact next higher level of maintenance. 	
2. NO OUTPUT.	<p>Step 1. Verify that front panel controls are set for the desired mode of operation.</p> <ul style="list-style-type: none"> • Set controls for desired operation. • If controls were correctly set, go to step 2. 	

Table 3-1. Troubleshooting (Continued)

Malfunction	Test or Inspection	Corrective Action
	Step 2.	<p>Check input/output coaxial cables.</p> <ul style="list-style-type: none"> • Substitute input/output cables one at a time. • If signal generator still inoperative, go to step 3.
	Step 3	<p>Check dial indicator light.</p> <ul style="list-style-type: none"> • If dial indicator light is lit, contact next higher level of maintenance. • If dial indicator light is not lit, go to procedure 1.
3. OVERLOAD INDICATOR IS LIT.		
		<p>Check that DC OFFSET control is in the OFF detent.</p> <ul style="list-style-type: none"> • Set DC OFFSET control to the OFF detent. • If DC OFFSET control was in the OFF detent, contact next higher level of maintenance.

Section V. MAINTENANCE PROCEDURES

3-10. GENERAL.

Organizational maintenance is limited to the replacement of fuses and knobs.

WARNING

High voltages are present when signal generator is plugged in to electrical power source. To prevent death or injury due to electrical shock, do not attempt to change fuse with signal generator plugged in.

CAUTION

For continued protection against fire when changing fuse, replace only with fuse of the specified voltage and current rating. Refer to table 2-3 for correct fuse value for each voltage card position.

CAUTION

Do not attempt to reinstall or align the Frequency Dial on this equipment. The pot and dial is a factory matched and calibrated assembly. If the frequency dial becomes loose or has been removed, the unit must be sent to calibration.

3-11. FUSE REPLACEMENT.

DESCRIPTION

This procedure covers: Remove. Install.

INITIAL SETUP

NOTE

PRELIMINARY PROCEDURE: Remove power from unit by disconnecting power cable at rear of instrument.

REMOVE

1. Disconnect power cord at instrument power receptacle (1).
2. Open fuse holder cover door (5) and rotate fuse-pull lever (4) to left.
3. Remove fuse (3) from fuseholder (2).

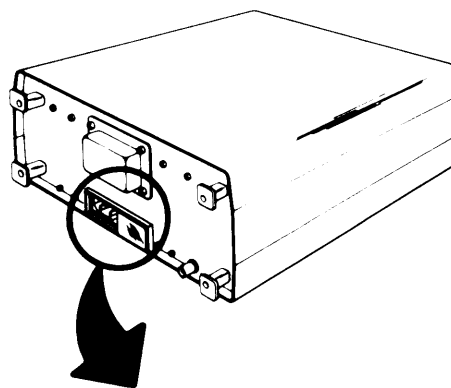

INSTALL

1. Rotate fuse-pull lever (4) back to normal position,
2. Insert new fuse (3) into fuse holder (2).
3. Slide cover door (5) to right to cover fuse holder (2).

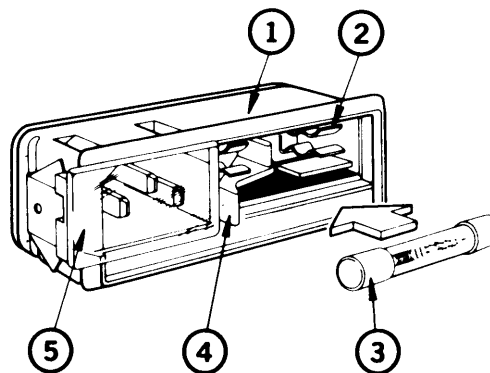

EL8ZX010

END OF TASK

3-12. REPLACE SINGLE FRONT PANEL KNOBS.

DESCRIPTION

This procedure covers: Remove. Install.

REMOVE

1. Set POWER switch (1) to OFF.
2. Loosen set screw (4).
3. Pull knob (3) off shaft (2).

INSTALL

1. Place knob (3) on shaft (2) and tighten set screw (4).
2. Rotate knob in direction called out in paragraph 3-14.
3. Without rotating control shaft (2), loosen set screw (4).
4. Align knob pointer (5) to front panel markings. (See paragraph 3-14).
5. Tighten set screw (4).

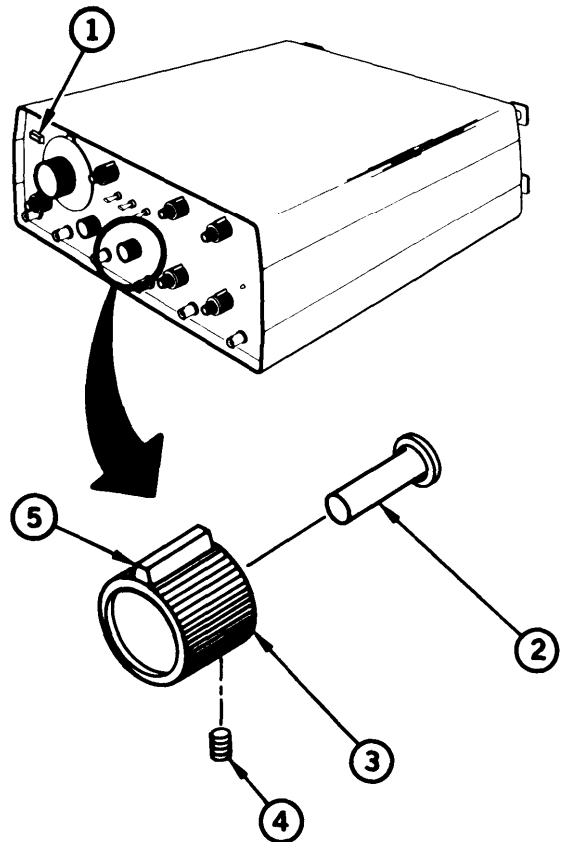

EL8ZX011

END OF TASK

3-13. REPLACE DUAL FRONT PANEL KNOBS.

DESCRIPTION

This procedure covers: Remove. Install.

NOTE

If front knob is to be removed, do steps 1 thru 4 of each procedure. If both knobs are to be removed, do steps 1 thru 8 of each procedure.

REMOVE

1. Set POWER switch (1) to OFF.
2. Loosen setscrew (7) on front knob (6).
3. Pull front knob (6) off of inner shaft (3),
4. Loosen setscrew (5) on rear knob (4).
5. Pull rear knob (4) off of outer shaft (2),

INSTALL

1. Place rear knob (4) on outer shaft (2).
2. Align pointer (9) on rear knob (4) to front panel marking. (See paragraph 3-14),
3. Tighten setscrew (5).
4. Rotate rear knob (4) and check that pointer (9) aligns with each front panel marking.
5. Place front knob (6) on inner shaft (3).
6. Align pointer (8) on front knob (6) to front panel marking. (See paragraph 3-14).
7. Tighten setscrew (7).

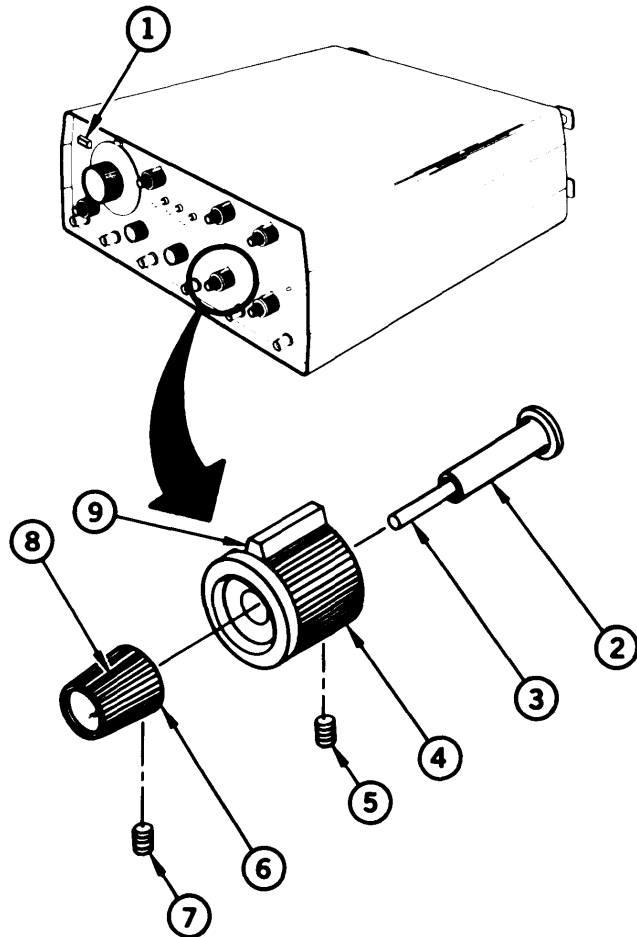

EL8ZX012

END OF TASK

3-14. KNOB ALIGNMENT.**DESCRIPTION**

This procedure covers: Remove. Install.

Knob alignment is performed using paragraph 3-12 or 3-13. Each knob is listed below by name, the direction of rotation, and the alignment marks used in these procedures. If you are uncertain of the knob name or it's location, refer to figure 2-1 and table 2-1.

Mode Switch	Full ccw	EXT GATE
TRIGGER LEVEL	Full ccw	MIN
FUNCTION (Modulation Generator)	Full ccw	
MOD AMPLITUDE	Full cw	MAX
FREQ/PERIOD MULT	Full ccw	Between .1/10 and 10/100m
VARIABLE	Full cw	MAX
ATTENUATION	Full cw	Between 80 and 60
AMPLITUDE	Full cw	MAX
FUNCTION (Main Generator)	Full ccw	DC
TRIG START/STOP	Full ccw	O°CAL
DC OFFSET	Full ccw	OFF
SYMMETRY	Full ccw	OFF
FREQ MULT	Full ccw	.01
VERNIER	Full cw	CAL

Section VI. PREPARATION FOR STORAGE OR SHIPMENT

3-15. PREPARATION FOR STORAGE OR SHIPMENT.

If the original packing material was saved, pack the instrument in same manner as received. When using packing materials other than the original, use the following guidelines:

- Wrap instrument in plastic packing material for protection against dust and moisture.
- Use double-wall cardboard shipping container.
- Protect all sides with shock-absorbing material such as styrofoam dunnage to prevent instrument movement within the container.
- Seal the shipping container with approved sealing tape.
- Mark FRAGILE on all sides, top and bottom of shipping container.

3-16. INFORMATION FOR STORAGE.

This instrument should be stored in a clean, dry environment. The following limitations apply to both storage and reshipment.

- Maintain temperature within – 55°C to + 75°C range.
- Relativity humidity not to exceed 95% at + 25°C and sea level (non-condensing).
- Altitude from sea level to 40,000 feet.

APPENDIX A REFERENCES

A-1 . SCOPE.

This appendix lists all of the forms, technical bulletins, technical manuals, and miscellaneous publications referenced in this manual.

A-2. FORMS.

Recommended Changes to Publications and Blank Forms	DA Form 2028
Recommended Changes to Equipment Technical Manuals	DA Form 2028-2
Equipment Inspection and Maintenance Work sheet	DA Form 2404
Quality Deficiency Report	Form SF 368
Report of Discrepancy	Form SF 364

A-3. TECHNICAL MANUALS.

The Army Maintenance Management System (TAMMS)	DA Pam 738-750
Procedures for Destruction of Electronics Material to Prevent Enemy Use (Electronics Command)	TM 750-244-2
Organizational, Direct Support, and General Support Repair Parts and Special Tools List for Signal Generator SG-1171/U	TM 11-6625-3051-24P
General Support Maintenance Manual for Signal Generator SG-1171/U	TM 11-6625-3051-40

A-4. MISCELLANEOUS PUBLICATIONS.

Common Table of Allowances	CTA 50-970
Consolidated Index of Army Publications and Blank Forms.	DA Pam 310-1
First Aid for Soldiers	FM 21-11
Abbreviations for Use on Drawings, Specifications, Standards and in Technical Documents	MIL-STD-12
Preservation, Packaging, Packing and Marking Materials, Supplies and Equipment Used by the Army	SB 38-100

APPENDIX B

MAINTENANCE ALLOCATION CHART (MAC)

Section I. INTRODUCTION

B-1 . GENERAL.

This appendix provides a summary of maintenance operations for Signal Generator SG-1171/U. It authorizes categories of maintenance for specific maintenance functions or repairable items and components, and the tools and equipment to perform each function. This appendix may be used as an aid in planning maintenance operations.

B-2. MAINTENANCE FUNCTION.

Maintenance functions will be limited to and defined as follows:

- a. *Inspect.* To determine the serviceability of an item by comparing its physical, mechanical, and/or electrical characteristics with established standards through examination.
- b. *Test.* To verify serviceability and to detect incipient failure by measuring the mechanical or electrical characteristics of an item and comparing those characteristics with prescribed standards.
- c. *Service.* Operations required periodically to keep an item in proper operating condition, i.e., to clean (decontaminate), to preserve, to drain, to paint, or to replenish fuel, lubricants, hydraulic fluid, or compressed air supplies.
- d. *Adjust.* To maintain, within prescribed limits, by bringing into proper or exact position, or by setting the operating characteristics to the specified parameters.
- e. *Align.* To adjust specified variable elements of an item to bring about optimum or desired performance.
- f. *Operate.* To determine and cause corrections to be made or to be adjusted on instruments or test, measuring, and diagnostic equipments used in precision measurement. Consists of comparisons of two instruments, one of which is a certified standard of known accuracy, to detect and adjust any discrepancy in the accuracy of the instrument being compared.
- g. *Install.* The act of emplacing, seating, or fixing into position an item, part, module (component or assembly) in a manner to allow the proper functioning of the equipment or system.
- h. *Replace.* The act of substituting a serviceable like type part, subassembly, or module (component or assembly) for an unserviceable counterpart.
- i. *Repair.* The application of maintenance services (inspect, test, service, adjust, align, calibrate, replace) or other maintenance actions (welding, grinding, revetting, straightening, facing, remachining, or resurfacing) to restore serviceability to an item by correcting specific damage, fault, malfunction, or failure in a part, subassembly, module (component or assembly), end item, or system.
- j. *Overhaul.* That maintenance effort (service/action), necessary to restore an item to a completely serviceable/operational condition as prescribed by maintenance standards (i.e., DMWR) in appropriate technical publications. Overhaul is normally the highest degree of maintenance performed by the Army. Overhaul does not normally return an item to like-new condition.

k. *Rebuild.* Consists of those services/actions necessary for the restoration of unserviceable equipment to a like-new condition in accordance with original manufacturing standards. Rebuild is the highest degree of materiel applied to Army equipment. The rebuild operation includes the act of returning to zero those age measurements (hours, miles, etc.) considered in classifying Army components.

B-3. MAC SECTION II COLUMN EXPLANATIONS.

The column headings used in section II of the MAC are defined as follows:

a. *Column 1, Group /Number.* Column 1 lists functional group code numbers, the purpose of which is to identify maintenance significant components, assemblies, subassemblies, and modules with the next higher assembly. End item group number shall be "00."

b. *Column 2, Component/Assembly.* Column 2 contains the names of components, assemblies, sub-assemblies, and modules for which maintenance is authorized.

c. *Column 3, Maintenance Function.* Column 3 lists the functions to be performed on the item listed in Column 2. (For detailed explanation of these functions, see paragraph B-2.)

d. *Column 4, Maintenance Category.* Column 4 specifies, by the listing of a work time figure in the appropriate subcolumn(s), the category of maintenance authorized to perform the function listed in Column 3. This figure represents the active time required to perform that maintenance function at the indicated category of maintenance. If the number or complexity of the tasks within the listed maintenance function vary at different maintenance categories, appropriate work time figures will be shown for each category. The work time figure represents the average time required to restore an item (assembly, subassembly, component, module, end item, or system) to a serviceable condition under typical field operating conditions. This time includes preparation time (including any necessary disassembly/assembly time), troubleshooting/fault location time, and quality assurance/quality control time in addition to the time required to perform the specific tasks identified for the maintenance functions authorized in the maintenance allocation chart. The symbol designators for the various maintenance categories are as follows:

- C Operator or Crew**
- O Organizational Maintenance**
- F Direct Support Maintenance**
- H General Support Maintenance**
- D Depot Maintenance**

e. *Column 5, Tools and Equipment.* Column 5 specifies by code, those common tool sets (not individual tools) and special tools, TM DE, and support equipment required to perform the designated function.

f. *Column 6, Remarks.* This column shall, when applicable, contain a letter code, in alphabetical order, which shall be keyed to the remarks contained in Section IV.

B-4. MAC SECTION III, TOOLS AND TEST EQUIPMENT, COLUMN EXPLANATIONS.

The column headings used in MAC section III are defined as follows:

a. *Column 1, Reference Code.* The tool and test equipment reference code correlates with a code used in the MAC, section II, Column 5.

- b. *Column 2, Maintenance Category.* The lowest category of maintenance authorized to use the tool or test equipment.
- c. *Column 3, Nomenclature.* Name or identification of the tool or test equipment.
- d. *Column 4, National Stock Number.* The National Stock Number of the tool or test equipment.
- e. *Column 5, Tool Number.* The manufacturers part number.

B-5. MAC SECTION IV, REMARKS, COLUMN EXPLANATIONS.

- a. *Column 1, Reference Codes.* This code recorded in column 6, Section II.
- b. *Column 2, Remarks.* This column lists information pertinent to the maintenance function being performed as indicated in the MAC, Section II.

**Section II. MAINTENANCE ALLOCATION CHART
FOR
SIGNAL GENERATOR, SG-1171/U**

(1) GROUP NUMBER	(2) COMPONENT/ ASSEMBLY	(3) MAINT. FUNCTION	(4) MAINTENANCE CATEGORY					(5) TOOLS AND EQUIPMENT	(6) REMARKS	
			C	O	F	H	D			
00	SIGNAL GENERATOR SG-1171/U	INSPECT	0.2	0.2				10 1,2,4,5,6,7,8, 11,12	A	
		ADJUST		0.3					B	
		ALIGN				2.0				
		SERVICE	0.1	0.1						C
01	MAIN BOARD PCA (A1)	REPAIR		0.1				1,2,3,4,5,6,7, 8,9,15,16,17 1,2,3,4,5,6,7, 8,11,12,13, 14,15 1,2,3,4,5,6,7, 8,9,15,16,17	D	
		TEST		0.1					E	
		REPAIR				4.0				F,H
		TEST					2.0			
02	AUXILIARY BOARD PCA (A2)	ALIGN						11,12	G	
		TEST				1.0				G
		REPAIR				1.0				G
03	FRONT PANEL ASSEMBLY (A3)	ALIGN						11,12	H	
		TEST				1.0				G
		REPAIR				1.0				G
04	REAR PANEL ASSEMBLY (A4)	TEST						11,12	H	
		REPAIR				1.0				G

**Section III. TOOL AND TEST EQUIPMENT REQUIREMENTS
FOR
SIGNAL GENERATOR, SG-1171/U**

TOOL OR TEST EQUIPMENT REF CODE	MAINT. CATEGORY	NOMENCLATURE	NATIONAL/ NATO STOCK NO.	TOOL NO.
1	H	50 OHM FEEDTHROUGH TERMINATION, TEK, P/N 011-0099-00	5985-00-213-7171	
2	H	BNC TO BNC 50 OHM COAXIAL CABLE, TEK. P/N 012-0057-01	6625-00-498-4834	
3	H	BNC TEE CONNECTOR, TEK, P/N 103-0030-00	5935-00-284-1962	
4	H	DIGITAL VOLTMETER, JF 8922A	6625-01-084-1760	
5	H	COUNTER, HP 5345A	6625-00-531-4752	
6	H	OSCILLOSCOPE, TEK SC504	6695-01-074-7954	
7	H	DISTORTION ANALYZER, HP 334A	6625-00-871-8012	
8	H	DUAL BANANA-TO-BNC ADAPTER, TEK, P/N 103-0090-00	5935-00-053-9454	
9	H	GENERATOR PULSE/FUNCTION, WAVETEK 145	6625-01-083-1725	
10	o	TOOL KIT, TK-101/G	5180-00-064-5178	
11	H	TOOL KIT, TK-105/G	5180-00-610-8177	
12	H	TOOL KIT, TK-100/G	5180-00-605-0079	
13	H	1X PROBE, TEK P6101 , P/N 010-6101-03	6625-01-119-0155	
14	H	MULTIMETER, SIMPSON 260-6	6625-00-238-1274	
15	H	DIGITAL MULTIMETER, HP-3490A	6625-00-557-8305	
16	H	VOLTAGE STANDARD, JF 332BAF	6625-00-150-6994	
17	H	DUMMY LOAD, 100 OHMS, 7910420-1 ELECTRIC	4931-00-932-7623	
18	H	DUMMY LOAD, 600 OHMS, 8898497 ELECTRIC	5985-00-617-0915	

Section IV. REMARKS

REFERENCE CODE	REMARKS
A	Inspect power cord, switches, BNC'S, voltage selector card, and exterior.
B	Adjust voltage selector card and knobs.
c	Clean exterior.
D	Replace fuse and/or knobs.
E	Performance test.
F	Troubleshoot.
G	Alignment and test of this module is only done in the end item.
H	Replace any part or assembly authorized.
I	If in storage more than 6 months, the instrument must pass performance test before deployment to the field. If it fails the test, it must be repaired.
J	The following module of the SG1171 is a throwaway and is included for completeness only: unit cover assembly (A5).

APPENDIX D ADDITIONAL AUTHORIZATION LIST

Section 1. INTRODUCTION

D-1. SCOPE

This appendix lists the additional items that you are authorized for the support of Signal Generator SG-1171/U.

D-2. GENERAL

This list identifies items that do not have to accompany Signal Generator SG-1171/U and that do not have to be turned with it. These items are all authorized to you by CTA, MTOE, TDA, or JTA.

D-3. EXPLANATION OF LISTING.

National stock numbers, description, and quantities are provided to help you identify and request the additional items you require to support this equipment. The items are listed in alphabetical sequence by item name under the type document (i.e., CTA, MTOE, TDA, or JTA) which authorizes the item(s) to you.

Section II. ADDITIONAL AUTHORIZATION LIST

(1) NATIONAL STOCK NUMBER	(2) DESCRIPTION		(3) U/M	(4) QTY AUTH.
	FSCM AND PART NUMBER	USABLE ON CODE		
	<i>MTOE AUTHORIZED ITEMS</i>			
5920-00-504-8634	FUSE, ¼ AMPERE, 250 VOLTS (7591 5) 313.250		EA	1
5920-00-199-9498	FUSE, ½ AMPERE, 250 VOLTS (7591 5) 313.500		EA	1

APPENDIX E

EXPENDABLE SUPPLIES AND MATERIALS LIST

Section 1. INTRODUCTION

E-1 . SCOPE.

This appendix lists expendable supplies and materials you will need to operate and maintain Signal Generator SG-1171/U. These items are authorized to you by CTA 50-970, Expendable Items (Except Medical, Class V, Repair Parts, and Heraldic Items).

E-2. EXPLANATION OF COLUMNS.

a. *Column (1) — Item Number.* This number is assigned to the entry in the listing and is referenced in the narrative instructions to identify the material (e.g. "Use cleaning compound, item 5, App. D").

b. *Column (2) — Level.* This column identifies the lowest level of maintenance that requires the listed item. (enter as applicable)

- C — Operator/Crew
- O — Organizational Maintenance
- F — Direct Support Maintenance
- H — General Support Maintenance

c. *Column (3) — National Stock Number.* This is the national stock number assigned to the item; use it to request or requisition the item.

d. *Column (4) — Description.* Indicates the federal item name and, if required, a description to identify the item. The last line for each item indicates the Federal Supply Code for the manufacturer (FSCM) in parentheses followed by the part number.

e. *Column (5) — Unit of Measure (U/M).* Indicates the measure used in performing the actual maintenance function. This measure is expressed by a two-character alphabetical abbreviation (e.g., ea, in, pr). If the unit of measure differs from the unit of issue, requisition the lowest unit of issue that will satisfy your requirements.

Section II. EXPENDABLE SUPPLIES AND MATERIALS

(1) ITEM NUMBER	(2) LEVEL	(3) NATIONAL STOCK NUMBER	(4) DESCRIPTION	(5) U/M
1	C,O	6850-00-105-3084	TRICHLOROTRIFLUOROETHANE (81 349) MIL-C-81 302	QT
2	C,O	8305-00-222-2423	CLOTH, LINT FREE (81349) MIL-C-13194	YD

INDEX

Subject	Paragraph Figure, Table, Number
A	
Abbreviations	1-9
Alignment, Knob	3-12, 3-13, 3-14
AMPLITUDE Control	2-1, F2-1 , T2-1
AM Switch	2-1, F2-1 , T2-1
ATTENUATION (dB) Control.	2-1, F2-1 , T2-1
C	
Capabilities and Features	1-10b
Card, Voltage	2-4, T2-3, 3-11
CAUTIONS	3-10
Characteristics, Performance	1-11
Characteristics	1-10a
Checking Unpacked Equipment	3-5
Cleaning2-3a, Appendix E
Common Names	1-8
Common Tools and EquipmentAppendix B
Conditions, Operating	
Unusual	2-6, 2-7, 2-8
Usual	2-4, 2-5, T2-4
Connectors	2-1,F2-1, T2-1
Continuous Mode	1-11, 1-13a, 2-5
Control Initial Setup	2-5a, T2-4
Controls, Indicators, and Connectors	2-1, F2-1 ,T2-1
Cross-Reference List	1-8
D	
Data, Equipment	1-11
DC OFFSET Control2-1,F2-1 , T2-1
Destruction of Army Materiel	1-4
Dimensions	1-11
E	
Equipment, Common Tools and	Appendix B
Equipment Data	1-11
Equipment Improvement Recommendation	1-6



E (Continued)

Equipment Purpose	1-1C
Equipment, Special Tools, TMDE and Support	Appendix B
External Gate Mode	1-11, 1-13c, 2-5e
External Trigger Mode	1-11, 1-13c, 2-5c
EXT MOD IN Connector	2-1, F2-1, T2-1
EXT TRIG IN Connector	2-1, F2-1, T2-1

F

Features	1-10C
First Aid	2-1, F2-1, T2-1
FM IN Connector	2-1, F2-1, T2-1
F M / S W P Switch	2-1, F2-1, T2-1
FREQ MULT (Hz) Switch	2-1, F2-1, T2-1
FREQ/PERIOD MULT (Hz) Switch	2-1, F2-1, T2-1
Frequency Dial	2-1, F2-1, T2-1
Frequency Range	1-11
FUNCTION Switch	
Main generator	2-1, F2-1, T2-1
Modulation generator	2-1, F2-1, T2-1
FUNCTION OUT (50Ω) Connector	2-1, F2-1, T2-1
Fuse Replacement	3-11

G

Gate Modes	
External	1-11, 2-5c
Internal	1-11, 2-5d
Generator, Signal	F1-1

H

High Voltage	3-11
--------------------	------

I

Internal Gate Mode	1-13d, 2-5d
Internal Trigger Mode	1-13b, 2-5b
Indicators	2-1, F2-1, T2-1
Input Connectors	2-1, F2-1, T2-1
Input Power Requirements	1-11
Inspections	2-3, T2-2
Internal Modes	1-11

K

Knob Alignment	3-12, 3-13, 3-14
Knob Replacement	3-12, 3-13

L

List of Abbreviations	1-9
List of Capabilities and Features	1-10b
List of Characteristics.	1-10a
List of Common Names	1-8
List of Control Initial Setup Positions	T2-4
List of Equipment Data.	1-11
List of Expendable Supplies and Materials	Appendix E
List of Knob Alignment	3-14
List of Operator Troubleshooting	37, 3-8, 3-9
List of PMCS Procedures	2-3, T2-2
List of References	Appendix A
List of Voltage Card Positions and Fuses	2-4, T2-3

M

Maintenance Allocation Chart (MAC)	Appendix B
Maintenance Forms, Records, and Reports	1-3
Maintenance, Operator Preventive	2-2, 2-3, T2-2
Maintenance Procedures	3-10, 3-11, 3-12, 3-13, 3-14
MOD AMPLITUDE Control	2-1, F2-1 , T2-1
Mode Switch	2-1, F2-1 , T2-1
Modulation Generator	1-11
Modulation Modes	1-11
MODULATION Switches	2-1, F2-1 , T2-1

N

Nomenclature Cross-Reference List	1-8
---	-----

O

Operational Modes	
Continuous	1-11, 2-5a
External Gate	1-11, 2-5e
External Trigger	1-11, 2-5c
Internal Gate.	1-11, 2-5d
Internal Trigger.	1-11, 2-5b
Operating Principles.	1-13
Operating Procedure.	2-5
Operation Requirements	1-11
Operator's Controls, Indicators, and Connectors	2-1, F2-1 , T2-1

0 (Continued)

OUT (600 Ω) Connector	2-1, F2-1 , T2-1
OVERLOAD Indicator	2-1, F2-1 ,T2-1

P

Parts, Repair	Appendix D
Performance Characteristics	1-11
PM(ϕ) Switch	2-1, F2-1 , T2-1
POWER OFF/ON Switch	2-1, F2-1 , T2-1
Power Receptacle	2-1, F2-1 , T2-1
Preparation for Storage or Shipment	1-5, 3-15
Preparation for Use.	2-4, T2-3
Preventive Maintenance	3-6
Preventive Maintenance, Operator's	2-2, 2-3, T2-2
Principles, Operating	1-13
Procedures, Operating	2-5, T2-4

R

Receptacle, Power	2-1, F2-1, T2-1
Records, Maintenance	1-3
References	Appendix A
Repair Parts	3-3
Replacement, Fuse	3-11
Replacement, Knob	3-12, 3-13
Reports, Maintenance	1-3
Requirements, Operating	1-11

S

Safety, Care, and Handling.	1-12
Setup, Control initial	2-5a, T2-4
Shipment	1-5, 3-15
Signal Generator SG1171/U	F1-1
Special Tools and Test Equipment	3-2, Appendix B
Storage	1-5, 3-15
SYNC IN Connector	2-1, F2-1, T2-1
SYNC OUT (TTL) Connector	2-1, F2-1, T2-1
SYMMETRY (FREQ ÷ I0) Control.	2-1, F2-1, T2-1

T

Test Equipment,	Appendix B
Tools, Common	Appendix B
Tools, Special	Appendix B

T (Continued)

TRIGGER LEVEL Control	2-1, F2-1, T2-1
TRIG START/STOP Control	2-1, F2-1, T2-1
Troubleshooting	3-7, 3-8, 3-9

U

Unpacking	3-4, 3-5, F3-1
Unusual Conditions	2-6, 2-7, 2-8

V

VARIABLE Control	2-1, F2-1, T2-1
VERNIER Control	2-1, F2-1, T2-1
Voltage Card	2-4, T2-3, 3-11
Voltage, High, Warning	3-10

W

WARNINGS	3-10
Warranty Information	1-7
Weight and Dimensions	1-11



THEN... JOT DOWN THE DOPE ABOUT IT ON THIS FORM. CAREFULLY TEAR IT OUT. FOLD IT AND DROP IT IN THE MAIL!

SOMETHING WRONG WITH THIS PUBLICATION?

FROM (PRINT YOUR UNIT'S COMPLETE ADDRESS)
 Commander
 Stateside Army Depot
 ATTN: AMSTA-US
 Stateside, N.J. 07703-5007

DATE SENT
 10 July 1975

PUBLICATION NUMBER
 TM 11-5840-340-12

PUBLICATION DATE
 23 Jan 74

PUBLICATION TITLE
 Radar Set AN/PRC-76

BE EXACT PIN-POINT WHERE IT IS

PAGE NO	PARA-GRAPH	FIGURE NO	TABLE NO
2-25	2-28		
3-10	3-3		3-1
5-6	5-8		
		F03	

IN THIS SPACE TELL WHAT IS WRONG AND WHAT SHOULD BE DONE ABOUT IT:

Recommend that the installation antenna alignment procedure be changed throughout to specify a 2° IFF antenna lag rather than 1°.

REASON: Experience has shown that with only a 1° lag, the antenna servo system is too sensitive to wind gusting in excess of 25 knots, and has a tendency to rapidly accelerate and decelerate as it hunts, causing strain to the drive train. Hunting is minimized by adjusting the lag to 2° without degradation of operation.

Item 5, Function column. Change "2 db" to "3db."

REASON: The adjustment procedure for the TRANS POWER FAULT indicator calls for a 3 db (500 watts) adjustment to light the TRANS POWER FAULT indicator.

Add new step f.1 to read, "Replace cover plate removed in step e.1, above."

REASON: To replace the cover plate.

Zone C 3. On J1-2, change "+24 VDC to "+5 VDC."

REASON: This is the output line of the 5 VDC power supply. +24 VDC is the input voltage.

TEAR ALONG PRIORITIZED LINE

PRINTED NAME, GRADE OR TITLE, AND TELEPHONE NUMBER
 SSG I. M. DeSpirito 999-1776

SIGN HERE

FILL IN YOUR
UNIT'S ADDRESS

FOLD BACK

DEPARTMENT OF THE ARMY

OFFICIAL BUSINESS

SAMPLE

Commander
US Army Communications-Electronics Command
and Fort Monmouth
ATTN: AMSEL-ME-MP
Fort Monmouth, New Jersey 07703-5007

TEAR ALONG PERFORATED LINE

RECOMMENDED CHANGES TO EQUIPMENT TECHNICAL PUBLICATIONS

SOMETHING WRONG WITH THIS PUBLICATION?



THEN...JOT DOWN THE DOPE ABOUT IT ON THIS FORM. CAREFULLY TEAR IT OUT, FOLD IT AND DROP IT IN THE MAIL.

FROM: (PRINT YOUR UNIT'S COMPLETE ADDRESS)

DATE SENT

PUBLICATION NUMBER

TM 11-6625-3051-12

PUBLICATION DATE

6 Sept 1985

PUBLICATION TITLE

Signal Generator SG-1171/U

BE EXACT PIN-POINT WHERE IT IS

PAGE
NO

PARA-
GRAPH

FIGURE
NO.

TABLE
NO.

**IN THIS SPACE TELL WHAT IS WRONG
AND WHAT SHOULD BE DONE ABOUT IT:**

PLEASE PRINT YOUR NAME

PRINTED NAME GRADE OR TITLE AND TELEPHONE NUMBER

SIGN HERE

DA FORM 1 JUL 79 2028-2

PREVIOUS EDITIONS ARE OBSOLETE

P.S. IF YOUR OUTFIT WANTS TO KNOW ABOUT YOUR RECOMMENDATION MAKE A CARBON COPE OF THIS AND GIVE IT TO YOUR HEADQUARTERS.

FILL IN YOUR
UNIT'S ADDRESS

FOLD BACK

DEPARTMENT OF THE ARMY

OFFICIAL BUSINESS

Commander
US Army Communications-Electronics Command
and Fort Monmouth
ATTN: AMSEL-ME-MP
Fort Monmouth, New Jersey 07703-5007

TEAR ALONG PERFORATED LINE

FILL IN YOUR
UNIT'S ADDRESS

FOLD BACK

DEPARTMENT OF THE ARMY

OFFICIAL BUSINESS

Commander
US Army Communications-Electronics Command
and Fort Monmouth
ATTN: AMSEL-ME-MP
Fort Monmouth, New Jersey 07703-5007

TEAR ALONG PERFORATED LINE

RECOMMENDED CHANGES TO EQUIPMENT TECHNICAL PUBLICATIONS



SOMETHING WRONG WITH THIS PUBLICATION?

THEN...JOT DOWN THE DOPE ABOUT IT ON THIS FORM. CAREFULLY TEAR IT OUT, FOLD IT AND DROP IT IN THE MAIL.

FROM: (PRINT YOUR UNIT'S COMPLETE ADDRESS)

DATE SENT

PUBLICATION NUMBER

TM 11-6625-3051-12

PUBLICATION DATE

6 Sept 1985

PUBLICATION TITLE

Signal Generator SG-1171/U

BE EXACT PIN-POINT WHERE IT IS

PAGE NO.	PARA-GRAPH	FIGURE NO.	TABLE NO.

IN THIS SPACE TELL WHAT IS WRONG AND WHAT SHOULD BE DONE ABOUT IT:

14 1/8 LONG PERFORATED LINE

PRINTED NAME GRADE OR TITLE AND TELEPHONE NUMBER

SIGN HERE

DA FORM 2028-2
1 JUL 79

PREVIOUS EDITIONS ARE OBSOLETE

P.S. IF YOUR OUTFIT WANTS TO KNOW ABOUT YOUR RECOMMENDATION MAKE A CARBON COPE OF THIS AND GIVE IT TO YOUR HEADQUARTERS.

FILL IN YOUR
UNIT'S ADDRESS

FOLD BACK

DEPARTMENT OF THE ARMY

OFFICIAL BUSINESS

Commander
US Army Communications-Electronics Command
and Fort Monmouth
ATTN: AMSEL-ME-MP
Fort Monmouth, New Jersey 07703-5007

TEAR ALONG PERFORATED LINE

By Order of the Secretary of the Army:

JOHN A. WICKHAM JR.
General, United States Army
Chief of Staff

Official:

DONALD J. DELANDRO
Brigadier General, United States Army
The Adjutant General

DISTRIBUTION:

To be distributed in accordance with DA Form 12-36 literature requirements for SG-1171/U.

